



Ladderfix
safe by design

84 FAIRHOLME AVENUE,
GIDEA PARK, ROMFORD
ESSEX RM2 5UX
Tel: 01708 451188
Fax: 01708 475113
E-mail: ladderfix@btconnect.com
www.ladderfix.co.uk

MICROLITE

INSTRUCTIONS

1. LADDERFIX MICROLITE

is suitable for use with all popular patterns of ladder which are properly erected on firm level ground or other proper base.

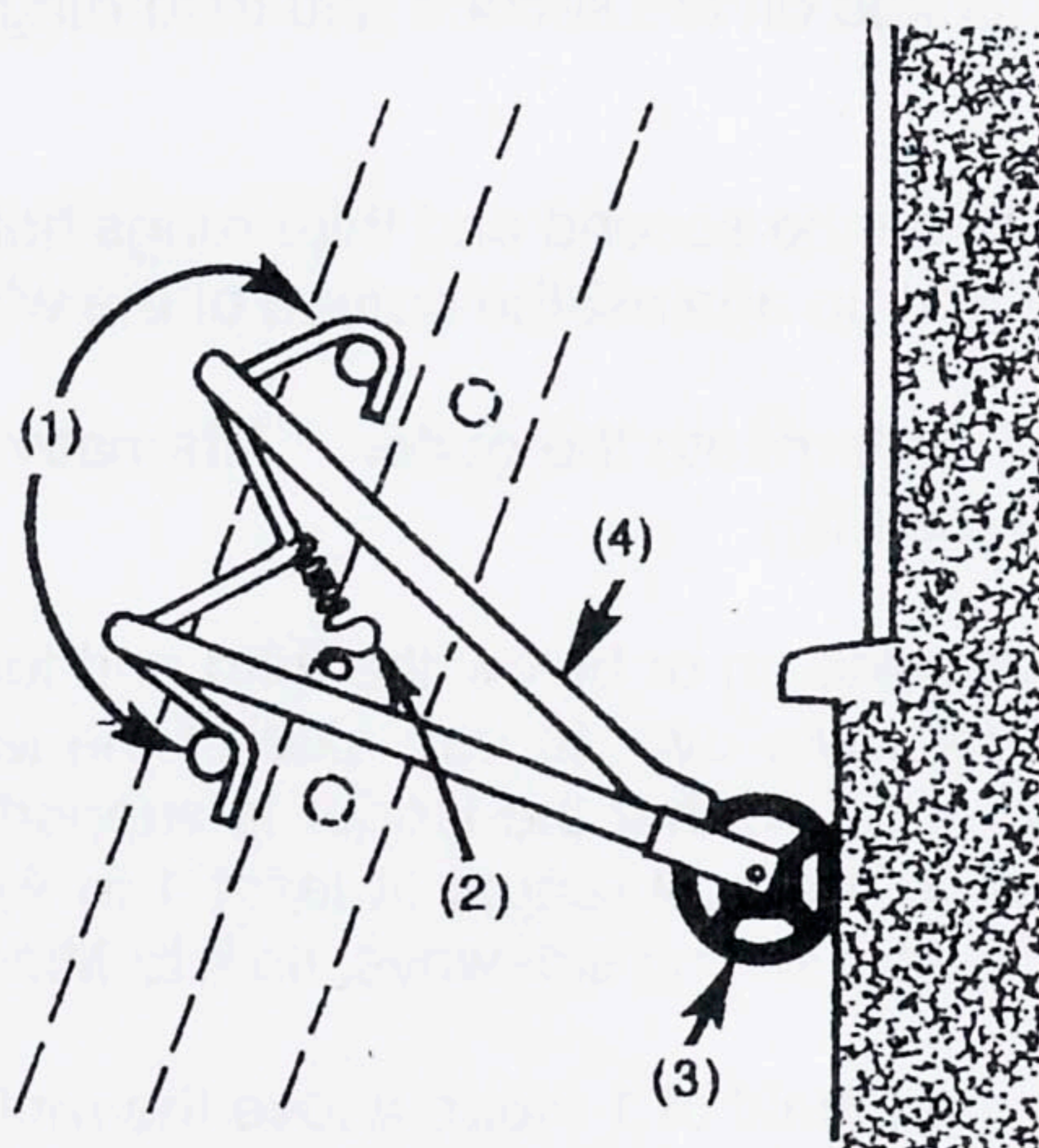

LADDERFIX MICROLITE
on walls.

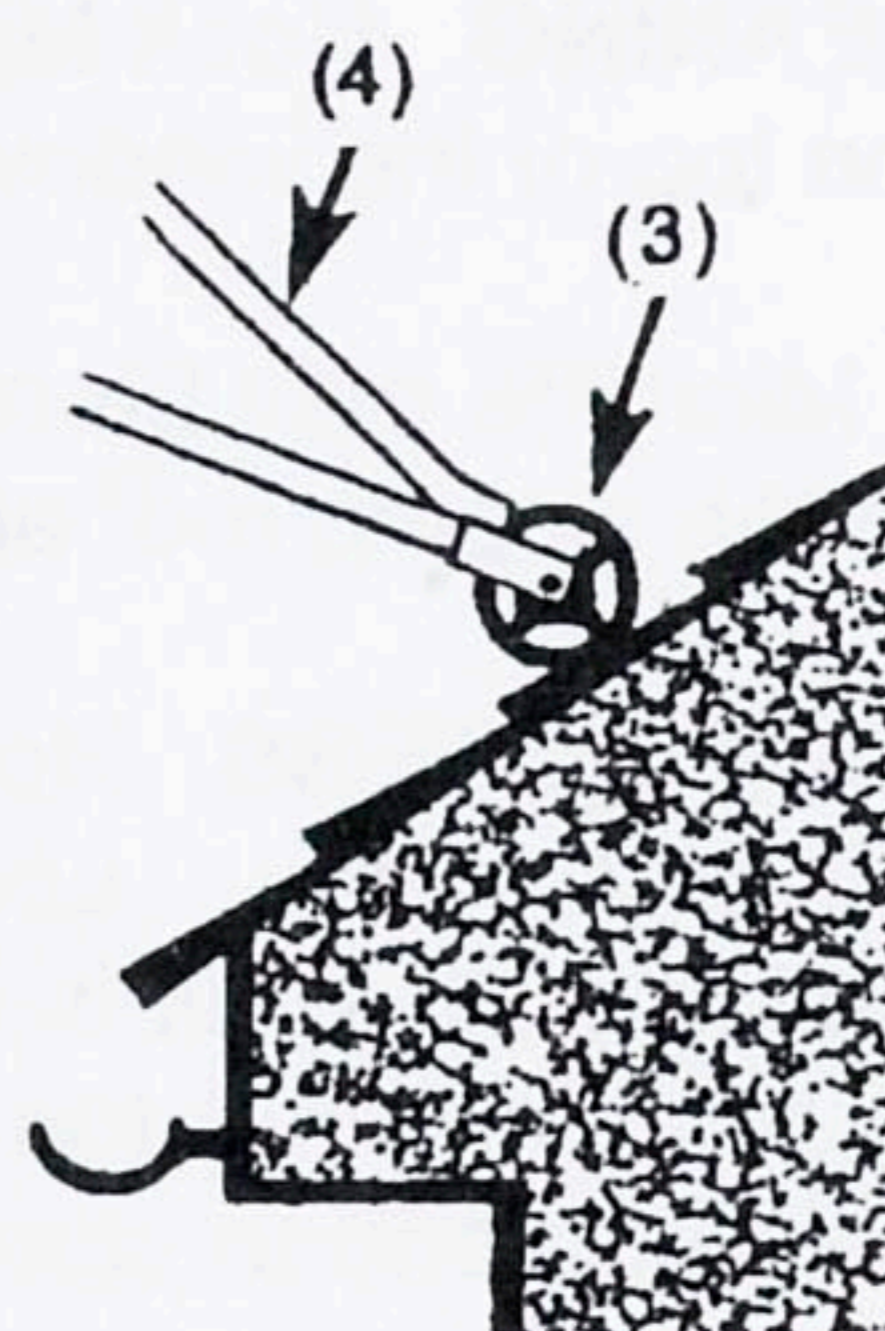

LADDERFIX MICROLITE
on sloping roofs.

WARNING

READ "SAFETY GUIDELINES" OVERLEAF IN CONJUNCTION
WITH INSTRUCTIONS OVERLEAF

LADDERFIX MICROLITE

1. **INSPECT.** Clean Ladderfix Compact (particularly corrosive materials such as cement) and check condition.

- 1.1 No damage such as dents, splits, holes, excessive wear, corrosion or gross distortion; minor distortion is acceptable providing Microlite sits evenly and has not been rebent after damage.
- 1.2 Both wheels are secure and undamaged and the tyres are clean and not loose, swollen, split or excessively worn.
- 1.3 Both spring clip assemblies are secure.
- 1.4 No repairs of any sort have been made.

2. **FIT** Ladderfix Microlite while ladder is on the ground – engage hooks (1) **over** two rungs near the top; engage spring clips (2) **under** the lower of the two rungs (some models have long and short settings – choose the one that gives positive grip with least tension).

3. **FOLLOW SAFETY GUIDELINES.**

4. **UP-END** ladder and extend to required height. If required, incline ladder somewhat more steeply than 1 in 4, check stability, stand on and roll top section up the wall.

5. **LADDER ANGLE.** Adjust to 1 in 4 and rest both wheels (3) firmly in position.

6. **WINDOWS.** Microlite is preferably hooked on the second and third rungs below the top and rested just below a window sill.

7. **WINDOW CLEANING.** Hook Microlite on the second and third rungs below the top and rest both wheels on top of the window sill and up against the bottom of the window frame.

8. **GUTTERS.** Microlite may be rested underneath the gutter. Alternatively, wheels can be rested firmly on the sloping roof above (see fig)

9. **SLOPING ROOF ACCESS.** Hook Microlite on or below the third and fourth rungs for a minimum handhold of 1 metre. Locate Microlite over to one side of the ladder for easier stepping off. Position both wheels on the roof so that the ladder is supported just clear of the gutter and the bottom is not too close to the wall (angle at least 1 in 4). Hook a roof ladder over the roof ridge and to stop its bottom sliding sideways, tie it to Microlite.

10. **FLAT ROOF ACCESS.** A minimum handhold of 1 metre above the roof and the stepping off rung is essential – hook Microlite on the ladder below the third and fourth rungs from the top if necessary. Rest the ladder stiles against the building if possible avoid gutters to prevent damaging them. To resist slip, keep the projecting limbs of Microlite as close over the roof top as possible.

11. **CARE.** Microlite is designed for **trade and industrial** use but it is **NOT** indestructible.

DO NOT jump or bounce your ladder top,
 DO NOT stand on the limbs of the Compact.
 DO NOT climb beyond the bottom hooks.
 DO NOT "bomb" your ladder.
 DO NOT leave your ladder unattended to get blown over.
 CLEAN OFF DEBRIS immediately, particularly corrosive materials such as cement and plaster.

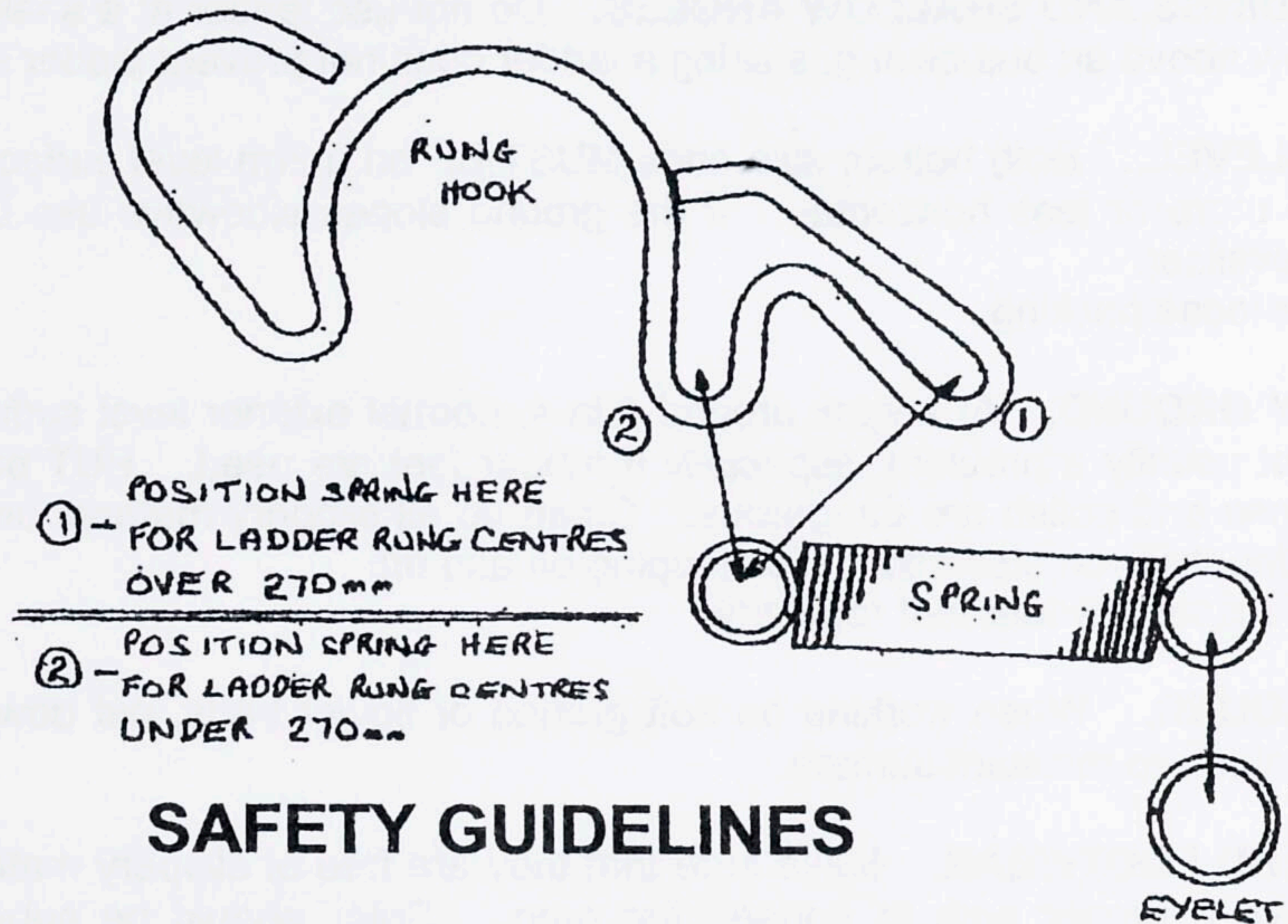

SAFETY GUIDELINES

THE WORK AT HEIGHT REGULATIONS 2005 should be observed at all times

SECURE ladders at the top with the appropriate Ladderfix model or by tying.

CAUTION. Ladderfix products are convenient and safe providing that they and your ladder are in good condition and they are used in accordance with safe codes of practice.

FURTHER USEFUL PRECAUTIONS

WINDS. Avoid using ladders if winds are more severe than a light breeze and be prepared for sudden gusts.

CARRYING LADDERS. Keep the ladder clear of the ground and obstructions, hesitate at steps, doorways and corners, and look in all directions before changing direction.

LOCATION. Do not erect ladder at doorways without taking particular precautions – ESPECIALLY FIRE EXITS. Make sure that ladder can be seen and avoided by pedestrians and vehicles. Corners are particularly risky. Do not forget about blind people and children.

UP-ENDING. Close the ladder as much as possible. Check for overhead cables, clothes lines, trees and other overhead obstructions, then check that the ground is reasonably clear. Because you may have repositioned the ladder, do the same when bringing the ladder down. Place bottom end against wall or kerb, lift the top end and walk forward holding the middle of each rung in turn, keeping the arms stretched up high. When the top of the ladder is at rest, bring the bottom outwards.

STABLE BASE. Do not erect on a box or a free standing tower.

LADDER ANGLE. Incline ladder at 1 in 4, i.e. 1 going 4 rising. Do not alter to compensate for poor site conditions.

OUTBUILDINGS AND SHALLOW ANGLES. Do not use ladder at a shallow angle to get to a window above an outbuilding, staking a ladder does not prevent ladder stress.

LADDER LEVEL.. Both bottom stile ends **MUST BE** on a firm level surface and the rungs should be more or less horizontal. If the ground slopes sideways use Ladderfix Safety Base or Leveliser.

Do not use loose packing.

SLIPPERY GROUND. At angles around 1 in 4, normal exterior level surfaces even when wet are not usually a problem, especially if rubber feet are used. **BUT** backward slopes, ice, oil, moss and polish are dangerous. Clean up all slippery material under and around not forgetting that you also might slip stepping on and off.

Clean and inspect Ladder feet regularly

SOFT GROUND. When working on soft ground or flower beds, put down a stout board with a suitable slip resistant surface.

RUNGS AND FOOTWEAR. Make sure that they are free of slippery material. Footwear should have a proper arch to engage the rung. Soles should be substantial to avoid discomfort.

Toes should be reinforced.

CLIMBING. Have at least one hand free to hold on. If you are climbing "one handed" hold the stile.

OVERLOADING. Do not exceed limits or allow more than one person on at a time.

HANDHOLD. Do not climb higher than 1 metre below the ladder top.

OVERREACHING. Do not allow both shoulders beyond one side of the ladder.

CAUTION. These SAFETY GUIDELINES are not an exhaustive list of precautions. They should not be taken as a substitute for any additional measures found necessary on site, nor do they guarantee that the use of a ladder is safe without regard to local conditions and are always subject to an employers risk assessment.

Ladderfix products are covered by various international patents. **Ladderfix, Microlite,**
And **Leveliser** are trade marks of **Ladderfix Ltd.**